

# Air Balancing Devices Opposed Blade Damper • Duct Mounted For Round Necks

Models: AG-75

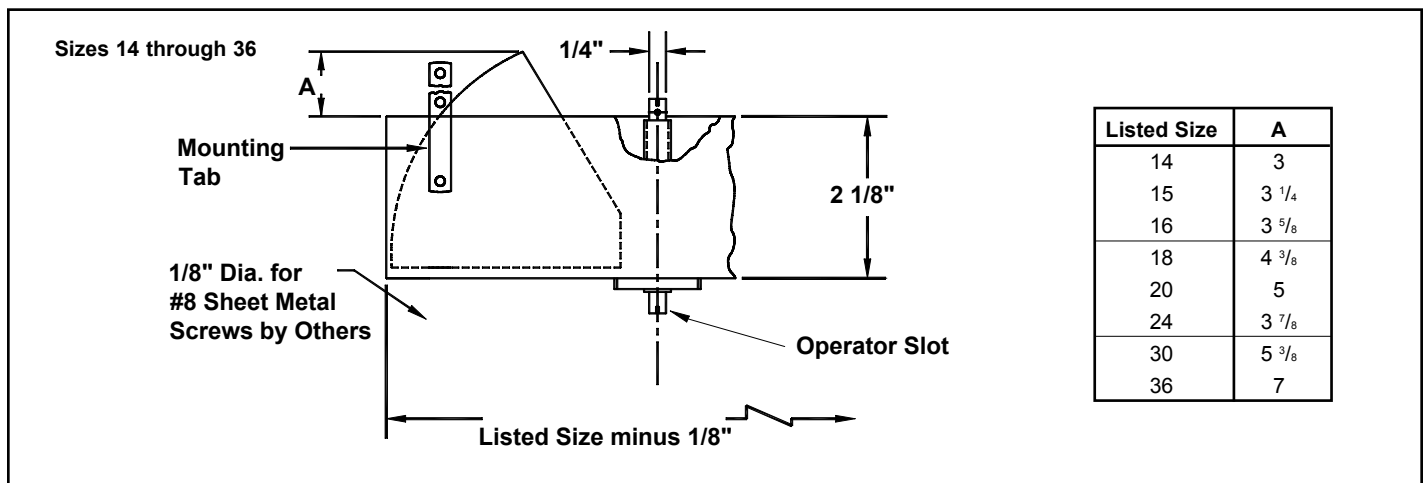
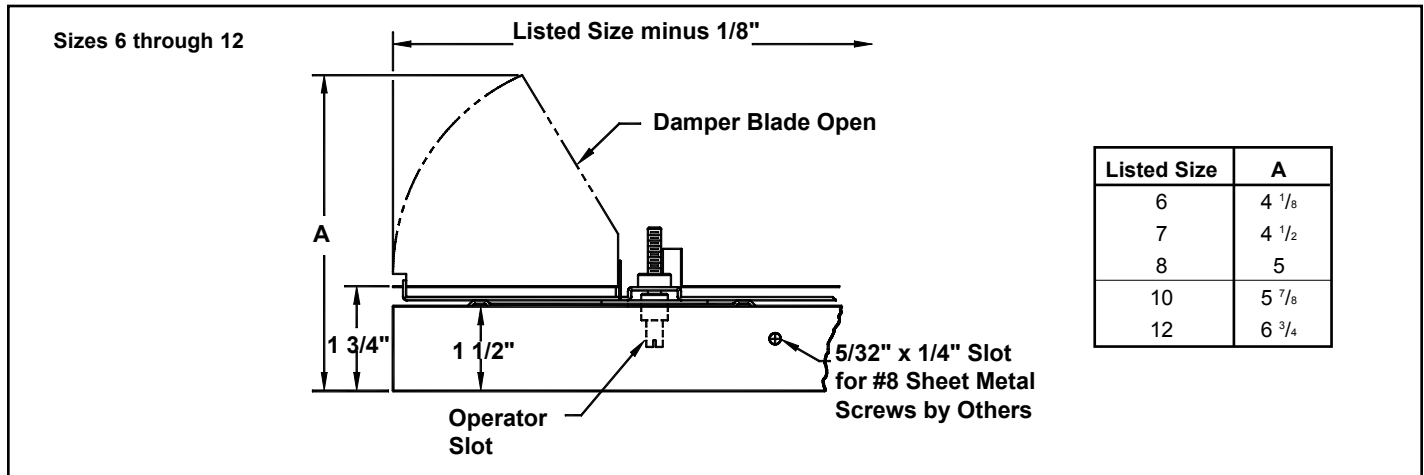

All dimensions are in inches.

**Standard Finish:** Mill

## General Description

- The TITUS AG-75 is a duct mounted opposed blade damper used in round duct application.

- Gang operated blades (3 sets on Sizes 6" - 12", 4 sets on Sizes 14" - 20", 6 sets on Sizes 24" - 36") distribute air evenly through the diffuser or duct. Not recommended for flexible duct applications.

- Adjustable at screwdriver operator slot.
- Shipped loose for field installation.
- Material is galvanized steel.